

Benha University
Faculty Of Engineering at Shoubra



ECE 122

Electrical Circuits (2)(2017/2018)

Lecture (7)

Magnetically Coupled Circuits (P.2)

Prepared By :

Dr. Moataz Elsherbini

motaz.ali@feng.bu.edu.eg

Example 1

Calculate the phasor currents I_1 and I_2 in the circuit below.

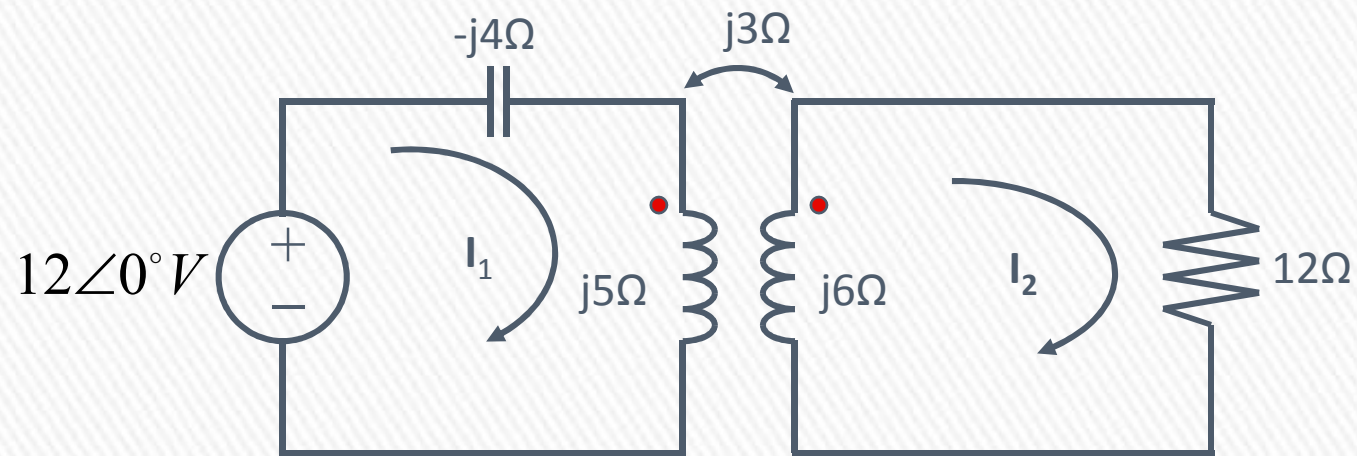

Solution

For coil 1, KVL gives

$$-12 + (-j4+j5)I_1 - j3I_2 = 0$$

Or

$$jI_1 - j3I_2 = 12$$



For coil 2, KVL gives

$$-j3I_1 + (12 + j6)I_2 = 0$$

Or

$$I_1 = \frac{(12 + j6)I_2}{j3} = (2 - j4)I_2$$



Substituting (2) Into (1)

$$(j2 + 4 - j3)I_2 = (4 - j)I_2 = 12$$

Or

$$I_2 = \frac{12}{4 - j} = 2.91 \angle 14.04^\circ \text{ A} \text{ --- (3)}$$

From eqn. (2) and (3)

$$\begin{aligned} I_1 &= (2 - j4)I_2 = (4.472 \angle -63.43^\circ) (2.91 \angle 14.04^\circ) \\ &= 13.01 \angle -49.39^\circ \text{ A} \end{aligned}$$

Mutual Coupling (Applications) (Transformers)

What is a transformer?

- » It is an electrical device designed on the basis of the concept of magnetic coupling
- » It uses magnetically coupled coils to transfer energy from one circuit to another
- » It is the key circuit elements for stepping up or stepping down ac voltages or currents, impedance matching, isolation, etc.

Application (Transformers)

Energy is transferred from the source to the load via the transformer's magnetic field with no electrical connection between the two sides.

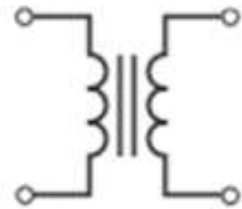

(a) Iron core

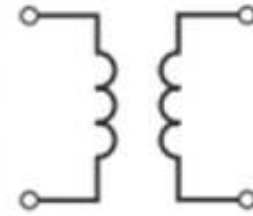

(b) Air core

**Iron-Core Transformers:
The Ideal Model**

**Air-Core Transformer:
Loosely Coupled Model**

Iron-Core Transformers: The Ideal Model

- Iron Core : All flux is confined to the core and links both windings. This is a “tightly coupled” transformer.
- It is described as Ideal: No power Loss

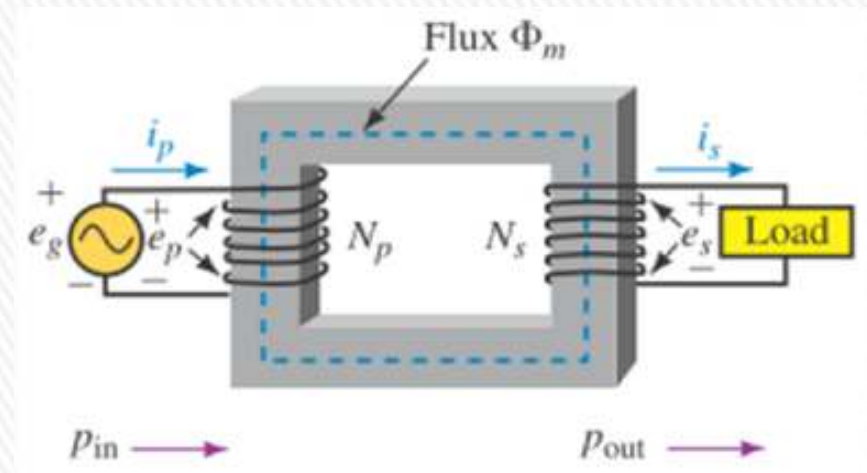

Voltage Ratio

$$e_p = N_p \frac{d\Phi_m}{dt}$$

$$e_s = N_s \frac{d\Phi_m}{dt}$$

Re-arrange rate of change of flux in one side in both equations:

$$\frac{e_p}{e_s} = \frac{N_p}{N_s}$$

This ratio is called the turns ratio (or transformation ratio) and is given the symbol a .

$$a = N_p / N_s$$

Step-Up and Step-Down Transformers

- A step-up transformer is one in which the secondary voltage is higher than the primary voltage, **(a < 1)**
- A step-down transformer is one in which the secondary voltage is lower. **(a > 1)**

Current Ratio

- Because an ideal transformer has no power loss, its efficiency is 100% and thus power in equals power out.

$$e_p i_p = e_s i_s$$

$$\frac{i_p}{i_s} = \frac{e_s}{e_p} = \frac{1}{a}$$

Reflected Impedance of Iron-core Transformer

- A transformer makes a load impedance look larger or smaller, depending on its turns ratio.
- When connected directly to the source, the load looks like impedance Z_L , but when connected through a transformer, it looks like $a^2 Z_L$.

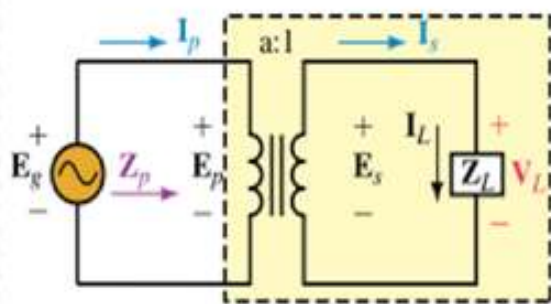

(a) Actual circuit

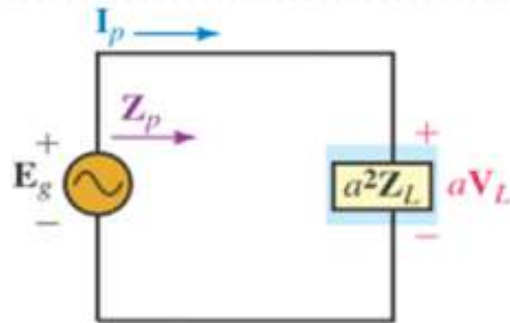

(b) Reflected impedance $Z_p = a^2 Z_L$

$$Z_p = \frac{E_p}{I_p} = \frac{aE_s}{\left(\frac{I_s}{a}\right)} = a^2 \frac{E_s}{I_s} = a^2 \frac{V_L}{I_L}$$

However $V_L/I_L = Z_L$. Thus,

$$Z_p = a^2 Z_L$$

Impedance Matching

- A transformer can be used to raise or lower the apparent impedance of a load by choice of turns ratio.
- This is referred to as impedance matching.
- Impedance matching is sometimes used to match loads to amplifiers to achieve maximum power transfer.

Example: If the speaker of Figure 23–29(a) has a resistance of 4 ohm, what transformer ratio should be chosen for max power? What is the power to the speaker?

Make the reflected resistance of the speaker equal to the internal (Thévenin) resistance of the amplifier.

$$Z_p = 400 \Omega = a^2 Z_L = a^2 (4 \Omega).$$

$$a = \sqrt{\frac{Z_p}{Z_L}} = \sqrt{\frac{400 \Omega}{4 \Omega}} = \sqrt{100} = 10$$

Since half the source voltage appears across it.

$$\text{power to } Z_p \text{ is } (40 \text{ V})^2 / (400 \Omega) = 4 \text{ W.}$$

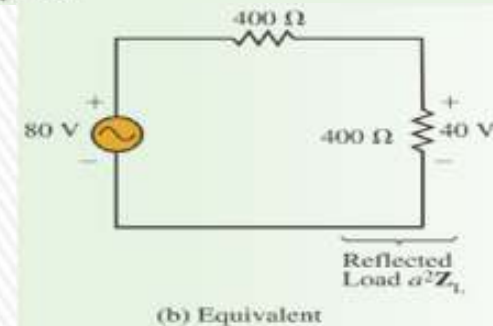
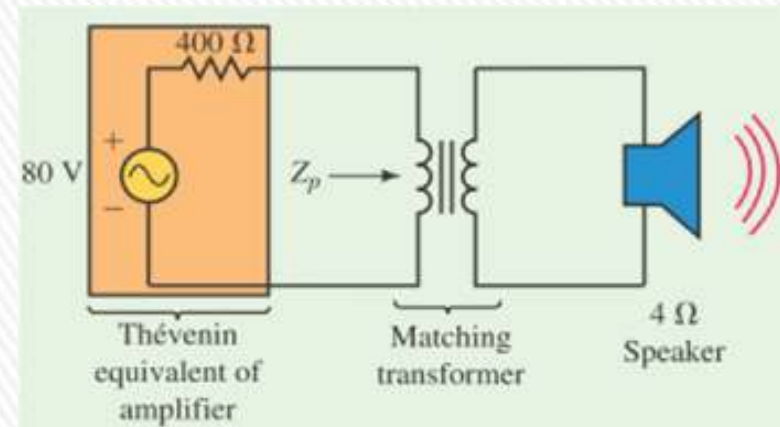

Transformer Applications

Applications

- » Transformer as an Isolation Device to isolate ac supply from a rectifier

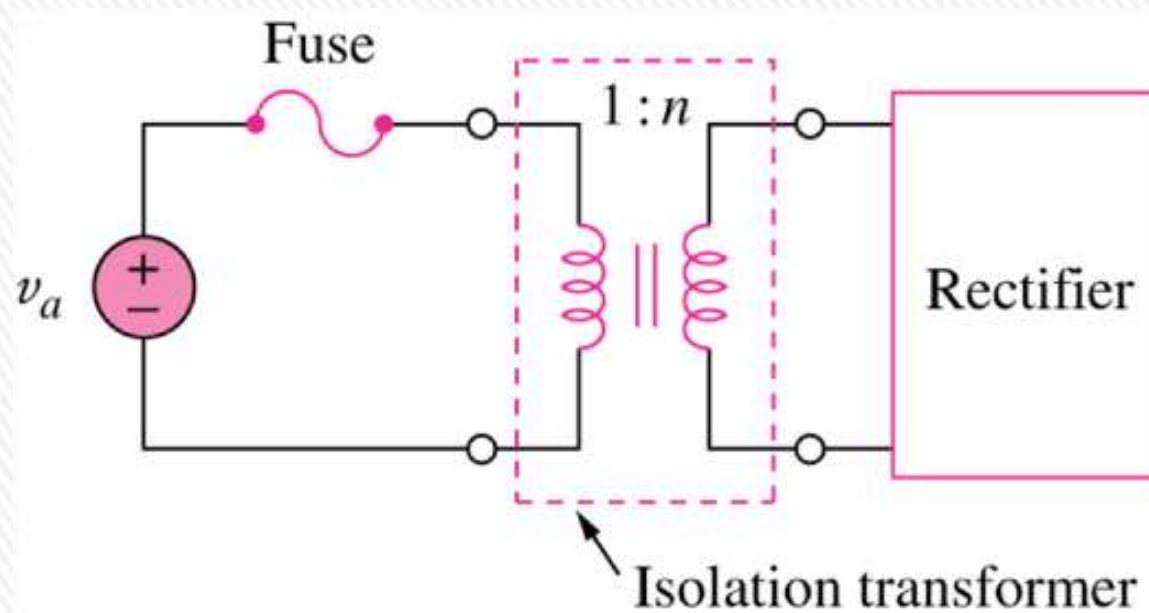

Applications

- » Transformer as an Isolation Device to isolate dc between two amplifier stages.

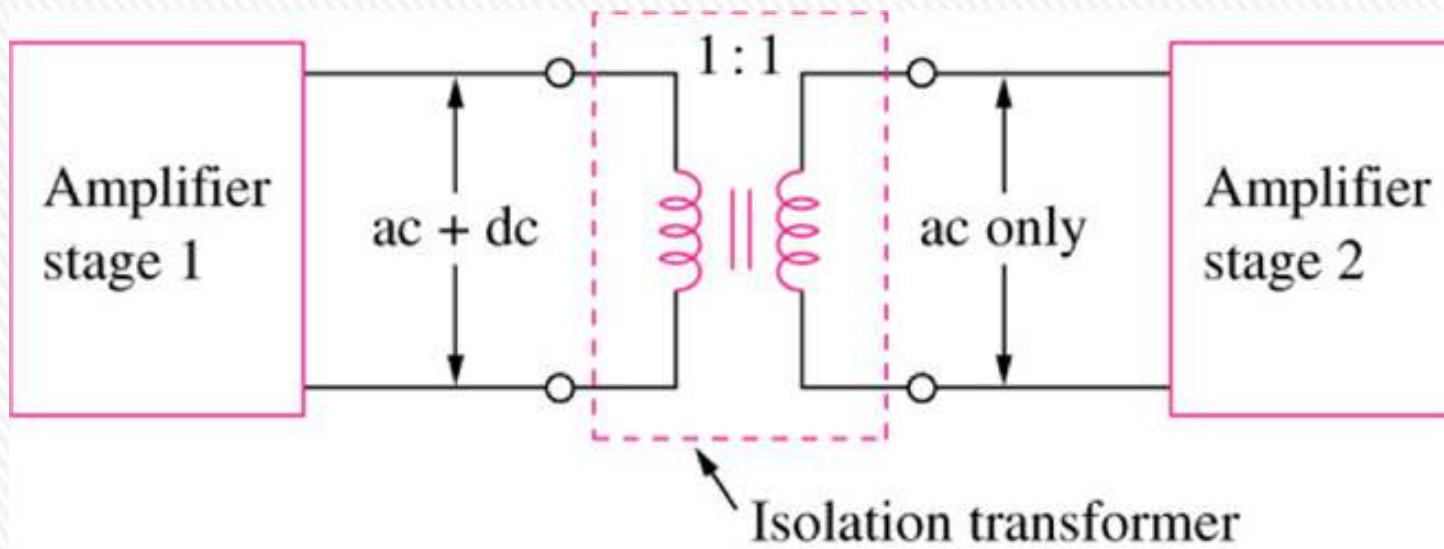

Applications

» Transformer as a Matching Device

Using an ideal transformer to match the speaker to the amplifier

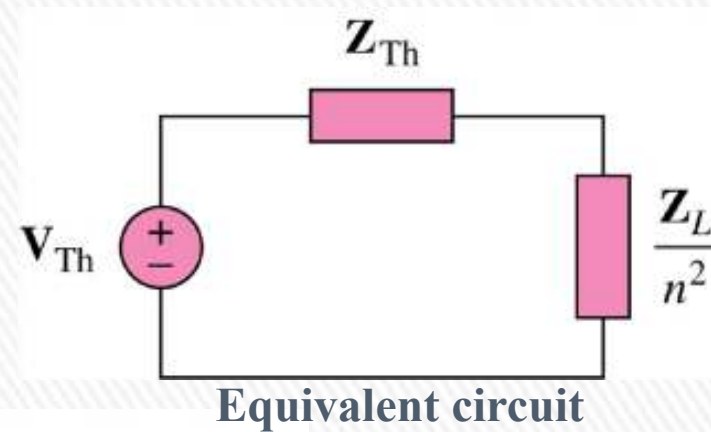
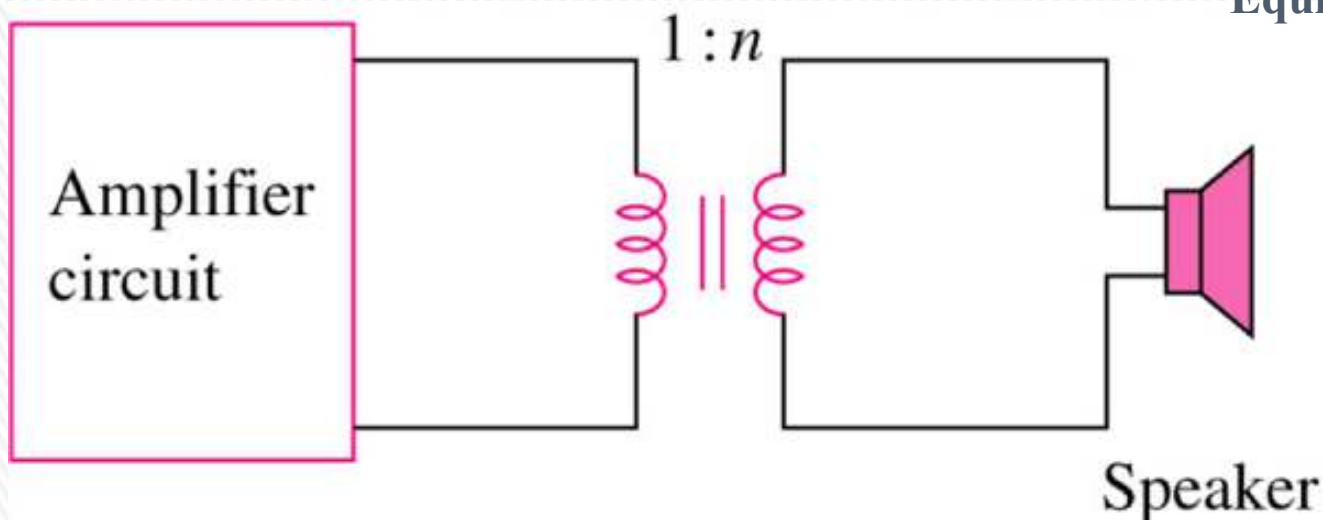

Applications

» A typical power distribution system

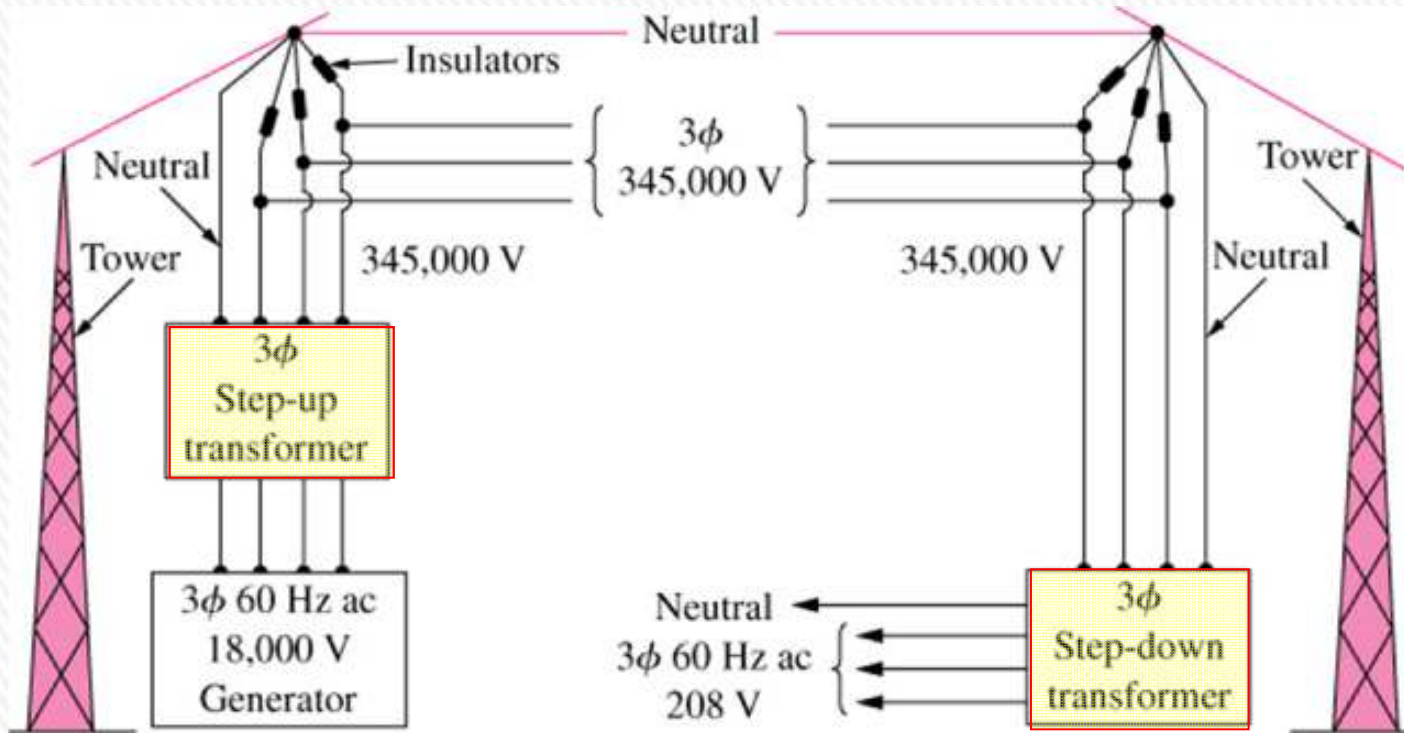

Example (2)

Example 4

An ideal transformer is rated at 2400/120V, 9.6 kVA, and has 50 turns on the secondary side.

Calculate:

- (a) the turns ratio,
- (b) the number of turns on the primary side, and
- (c) the current ratings for the primary and secondary windings.

Ans:

- (a) This is a step-down transformer, $n=20$
- (b) $N_1 = 1000$ turns
- (c) $I_1 = 4A$ and $I_2 = 80A$

Example (2)

Find impedance faced by voltage source V in the circuit

Sol

From figure $V = V_{ab} = 20 I_x \rightarrow \textcircled{1}$

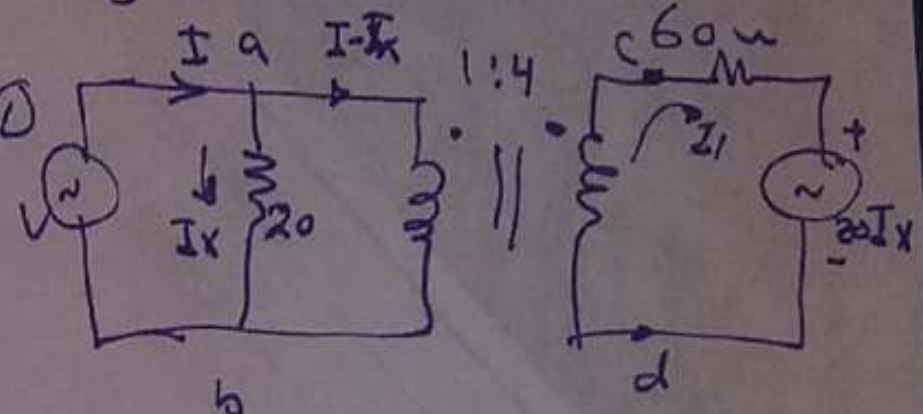

→ Current Through Primary
 $= I - I_x = I_p$

$$\therefore \frac{N_p}{N_s} = \frac{I_s}{I_p} = \frac{1}{4} = \frac{I_s}{I - I_x}$$

$$\rightarrow I_s = \frac{I - 2x}{4} = I_1 \rightarrow \textcircled{2}$$

$$\rightarrow \frac{N_p}{N_s} = \frac{1}{4} = \frac{V_p}{V_s} = \frac{V}{V_{cd}}$$

Example (2)

$$\frac{N_p}{N_s} = \frac{V_p}{V_s} = \frac{V}{V_{cd}}$$

$$\therefore V_{cd} = 4V = \underbrace{I_s \times 60}_{I_R} + 20I_x = 60 \times \frac{I - I_x}{4} + 20I_x$$

$$\therefore 4V = 15(I - I_x) + 20I_x$$

from (1)

$$4V = 15I - \underbrace{15I_x + 20I_x}_{5I_x}$$

$$4V = 15I + 5\left(\frac{V}{20}\right)$$

$$\therefore V = 4I \quad \therefore \frac{V}{I} = 4 = \text{impedance}$$

Thank You

